

Front view and mounting

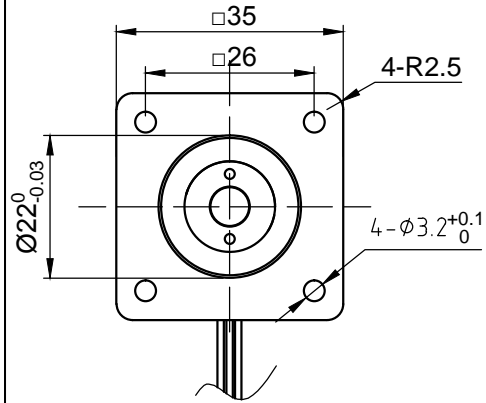

Side view

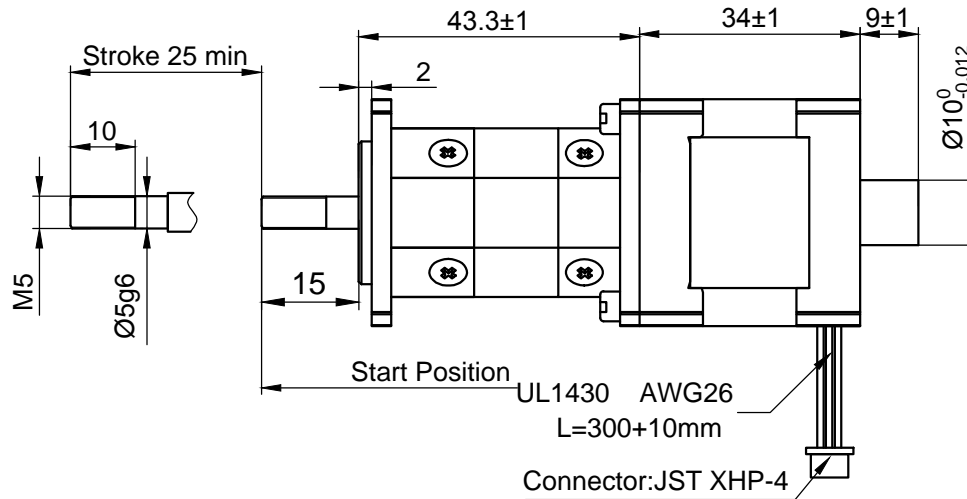

Rear view

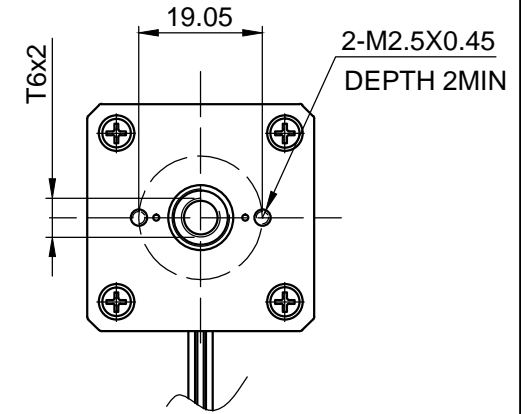

SPECIFICATION	
AMPS/PHASE	1.2
RESISTANCE/PHASE (Ohms)@25°C	1.85±15%
INDUCTANCE/PHASE (mH) @1KHz	2.0±20%
SPINDLE PITCH (mm) [in]	2 [0.07874]
THRUST (N) [lbf]	160[35.97]
RESOLUTION (mm/FULLSTEP)	0.01
STATIC THRUST (N) [lbf] (NO CURRENT)	>160
MAX. SPEED (mm/sec.) AT 48V	100
MAX. SPEED WITH MAX. THRUST (mm/sec.) AT 48V	12
WEIGHT (Kg) [lb]	0.2[0.44]
TEMPERATURE RISE: MAX.80°C (MOTOR STANDSTILL; FOR 2 PHASE ENERGIZED)	
AMBIENT TEMPERATURE -10°~ 50°C [14°F ~ 122°F]	
INSULATION RESISTANCE 100 MOhm (UNDER NORMAL TEMPERATURE AND HUMIDITY)	
INSULATION CLASS B 130° [266°F]	
DIELECTRIC STRENGTH 500VAC FOR 1 MIN. (BETWEEN THE MOTOR COILS AND THE MOTOR CASE)	
AMBIENT HUMIDITY MAX. 85% (NO CONDENSATION)	

Please regard the application note at www.nanotec.com for further informations.

Shaft play is adjustable at the motor.

PIN NO	TYPE OF CONNECTION (EXTERN)		MOTOR	
	BIPOLAR	LEADS	WINDING	
1	A —	BK	A	
2	A\ —	GN	A\	
3	B —	RD	B	
4	B\ —	BU	B\	

WIRING DIAGRAM

FULL STEP 2 PHASE-Ex., WHEN FACING MOUNTING END (X)

STEP	A	B	A\	B\		CCW
1	+	+	-	-	↓	↑
2	-	+	+	-		
3	-	-	+	+	↑	↓
4	+	-	-	+		

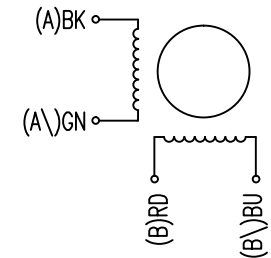

REV	DESCRIPTION	DATE	APVD	 Nanotec PLUG & DRIVE			SCALE FREE	APVD	G.S.	26.11.13	LINEAR MOTOR DWG.NO L3518S1204-T6x2-A25
						X ±0.5	CHKD	GYQ	26.11.13		
						1PL ±0.2	DRN	L B	26.11.13		
						2PL ±0.1	SIGNATURE		DATE		
						ANGLE ±30'					